

Max Charge MC-612 Regulator Installation and Operator's Manual

BALMAR®

I. INTRODUCTION

The microprocessor-controlled Max Charge MC-612 is the most advanced regulator available. Designed to continually monitor battery voltage and automatically optimize charging, the MC-612 uses up to 12 time and voltage increments to ensure your batteries receive a full charge quickly and safely.

The MC-612 lets you choose from a variety of selectable preset programs to best suit your charging needs. **Its Universal Factory Program allows you to connect the MC-612 to your alternator right out of the box.** Six additional preset programs support most popular battery types, including standard and deep-cycle flooded batteries, AGM, gel, and Optima (spiral wound) technologies. An easy-to-use magnetic reed switch delivers quick, precise regulator adjustment. Should your charging system require individualized adjustment, the MC-612 provides additional user-defined programming options.

When used with optional alternator and battery temperature sensors, the MC-612 automatically monitors ambient temperatures and compensates for over-temperature conditions by reducing field output. Alarm outputs connect to audible or visual alarms to warn of dangerous system conditions.

II. SAFETY CONSIDERATIONS

Before installing your MC-612 marine regulator, please take a moment to consider these guidelines for safe regulator installation. Failure to work safely could result in personal injury or damage to your electrical system.

1. Always disconnect your battery banks and ensure that switches are "OFF" prior to installing your regulator.
2. Remove loose-fitting clothing or jewelry, which could become entangled in your motor or other machinery.
3. Wear ANSI-approved safety glasses.
4. DO NOT attempt to modify the regulator. Alterations could result in damage to your charging system, and will void your warranty.
5. Do not attempt installation if tired or fatigued.
6. Ensure the engine has cooled before initiating installation.
7. Do not attempt installation while using alcohol or any medication that could impair your judgment or reaction time.
8. Always use the right tool for the job. Improper tool use may damage the regulator or your boat, and could result in personal injury.
9. Take time to read the manual. Equipment damage and possible injuries may result from an incomplete understanding of the installation and operation of the MC-612 regulator. If you are unfamiliar with marine electrical systems, consult with a licensed marine electrician.

III. BASIC INSTALLATION

The MC-612 can be purchased with or without a standard 54" harness. When installing without the harness, or if the wiring needs to be extended beyond the length of the harness, marine grade 12AWG (American Wire Gauge) wire should be used.



CAUTION

The following instructions are intended for use by experienced marine electrical installers. If you are not experienced at installing electrical system components, we recommend the use of a qualified marine electrical technician.

TABLE OF CONTENTS

I.	Introduction
II.	Safety Considerations
III.	Basic Installation
IV.	Alarm and Sensor Installation
V.	Short Display
VI.	Preset Battery Programming
VII.	Long Display
VIII.	Advanced Programming Amp Manager Equalization System Diagnostics
IX.	Troubleshooting Warranty
	Sample System Wiring Single Output Alternator Dual Output Alternator Express Installation Instructions

BALMAR®
FAX: (360) 435-3210

19009 61st Ave. NE, Arlington, WA 98223
E-MAIL: balmar@balmar.net

PHONE: (360) 435-6100
WEB: WWW.BALMAR.NET

©Copyright 2001 Ballard Commercial Industries, Inc. Revised 3/15/2002

To install the regulator:

1. Mount the regulator in a dry, well-ventilated location, well away from hoses and exhaust manifolds which may cause damage to the regulator or wiring. Avoid areas of heat and/or high vibration.
2. The RED wire (in the harness) powers the regulator. Attach at the positive output terminal at the back of the alternator. If an isolator is used, this wire must be located on the battery side of the isolator. On a 12V system, this wire can carry 8 amps and must be protected by a 10-amp fuse. A fuse is included with the wiring harness.
3. The POSITIVE battery sense wire, as shown in the illustration at right, monitors battery voltage. The positive and negative sense wires **MUST** be connected for the regulator to work. The positive sense wire should be connected 1) at the battery, if only one battery bank is used; 2) at the "common" terminal of the battery selector switch for multi-bank charging; or 3) on the isolator terminal for the largest battery bank (if isolator is used). This wire is user supplied and should be 14 -gauge (minimum). Spade and ring terminals, and a 1-A mini fuse pigtail are provided. Refer to regulator side label, or Figure 3 below for terminal locations. Caution: Sense wires **MUST** always see the battery being charged. Be sure to observe polarity when connecting. When connected, the Positive Battery Sense draws approximately .53mA .
4. The BROWN (ignition) wire activates the regulator when +12VDC is applied to the system. Attach the BROWN wire to a switched +12VDC source. The auxiliary side of the ignition switch, or an independent (ungrounded) oil pressure switch are both acceptable connection points. A toggle switch may be added to this circuit to shut down the alternator load in cases where maximum propulsion is needed.
5. Attach the Ford-type harness plug to the regulator (see illustration). The second BLACK (ground) wire in the harness attaches to the Negative Battery Sense Terminal. Both BLACK wires attach to preferred ground terminal on the alternator. A (user supplied) ground strap between the alternator and the preferred ground at the engine is also strongly recommended.
6. Plug duplex connector with BLUE (field) and White (stator) wires into rear of alternator.
7. If you are using an electrical tachometer that is being driven off of your alternator's stator pulse, plug the white stator wire into the terminal provided on the regulator, and the tach feed into the Tach Out terminal. If you are not using the stator pulse to drive your tachometer, **DO NOT** plug the stator wire into the regulator's Stator connection, as the attachment of the stator wire to the regulator tells the regulator that it is necessary to continue to provide a voltage pulse to maintain a tach signal, even if the batteries are fully charged.

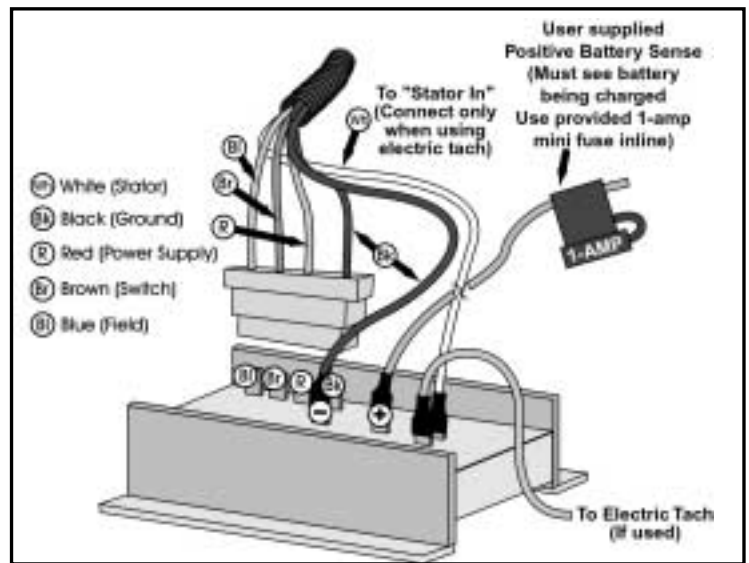

Figure 1 - Regulator wiring attachment.

Length Amps	10 Ft.	15 Ft.	20 Ft.	25 Ft.	50 Ft.	75 Ft.	100 Ft.
25	10	8	8	6	4	2	1
50	8	6	4	4	1	2/0	3/0
75	6	4	2	2	2/0	3/0	4/0
100	4	2	2	1	3/0	4/0	
125	4	2	1	1/0	3/0	4/0	
150	2	1	1/0	2/0	4/0		
175	2	1/0	2/0	3/0			
200	2	1/0	2/0	3/0			
225	1	2/0	3/0	4/0			
250	1	2/0	3/0	4/0			
275	1/0	2/0	4/0				
300	1/0	3/0	4/0				
325	1/0	3/0	4/0				
350	2/0	3/0					
375	2/0	4/0					

Figure 2 - Wire size chart. Represents 3% voltage drop. Lengths should be measured in round trip.

When using the alternator and regulator to drive your tachometer, there is a possibility that you will see system voltage creeping up when your batteries are fully charged. This occurs as a result of the regulator's effort to provide a "blip" of voltage to the alternator to keep the tachometer feed activated. This voltage creep can usually be reduced or eliminated by increasing the load on the batteries, i.e., turning on a few cabin lights or cabin fans, until the batteries are allowed to accept charging voltage.

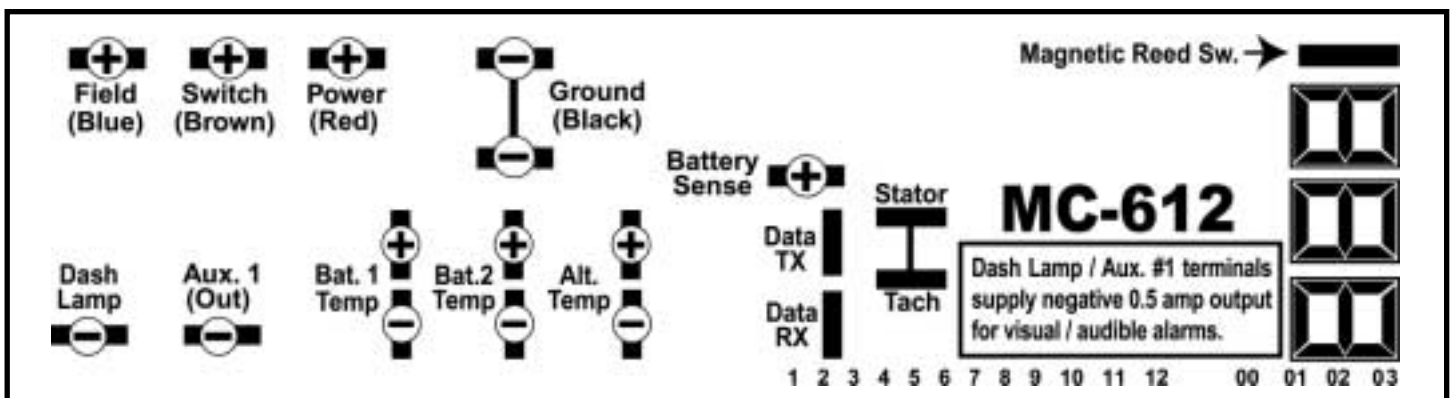

Figure 3 - Regulator terminal layout.

IV. ALARM AND SENSOR INSTALLATION

Alternator Temperature Sensor (MC-TS-A) - Optional

The Alternator Temperature Sensor enables the regulator to sense when the alternator temperature exceeds safe working limits. The MC-612 responds by reducing the field current at the alternator and activating the alarm output. To install the Alternator Temperature Sensor:

1. Attach the positive and negative wires to the Alternator Temperature Sensor terminals on the MC-612 (See Figure 4). Observe proper polarity at the terminals.
2. Attach the heavy lug terminal to a location described below on your alternator. Flat washers are included with the temperature sensors to ensure solid mounting connections. The following are typical installation locations:

MID CASE MOUNT - Small Case Alternator - Remove (1) of (4) 5/32" Allen bolts, install probe, re-secure bolt. (See Figure 5.)

MID CASE MOUNT - Large Case Alternator - Remove (1) of (4) 3/16" Allen bolts, install probe, re-secure bolt.

Caution: The alternator temperature sensor is not meant to be used as a method to maintain alternator temperature. Optional temperature sensors are not a guarantee of protection against damage from over-heat conditions. Inspect your system as quickly as possible if the sensor alarm is activated. Have your system inspected if overheating occurs.

Battery Temperature Sensor (MC-TS-B) - Optional

When equipped with the optional Battery Temperature Sensor, the MC-612 will automatically compensate for variation above and below normal ambient temperatures. The MC-612 is equipped with dual battery sensors to enable sensing at two separate batteries. To ensure proper operation, be sure the battery terminals are completely clean and free of corrosion prior to installation. To install the Battery Temperature Sensor:

1. Secure the 3/8" copper probe to a clean negative (-) battery terminal (see Figure 6). The 20' leads may be shortened or extended, if needed. Note: An improperly installed or corroded battery terminal may generate heat and severely diminish charging and impede accurate temperature sensing.
2. While observing polarity, connect the battery temperature pins to the positive and negative terminals as shown on Figure 4.

Note: Battery #1 terminal is capable of temperature compensation and activating warning alarm. Battery #2 terminal activates the warning alarm only. The upper voltage limit for battery compensation is 14.8 volts. If higher voltage limits are desired, adjust voltage levels in the Compensation Limit (CL) mode of the advanced programming adjustments.

Lamp / Alarm Outputs

The MC-612 includes two output terminals, one for system alarms (dash lamp) and another for advisory information (Aux. #1). These terminals output battery negative (0.5-amp max) when in alarm condition. Refer to Figure 7 for common system conditions that may initiate an alarm. When in the alarm mode, the 3-digit numeric display will indicate the exact cause for the alarm. Specific advisory codes are shown in Figure 17 on Page 6.

Small Engine Mode

The MC-612 can be modified to provide a half-power setting by installing a toggle switch between the positive and negative terminals of the alternator temperature sensor circuit. When activated by closing the switch, the regulator reduces the alternator output by approximately 50%. This mode is ideal for smaller engines that are not capable of providing suitable horsepower to drive both the alternator and propeller at full output. When in Small Engine Mode, the regulator will send a signal to the Auxiliary #1 Status Output.

V. SHORT DISPLAY

The Model MC-612 provides a wide range of operational, programming and diagnostic data through its 3-digit numeric LED read-out. After an initial start-up period, the numeric LED will cycle through the Short Display, shown in Figure 8 on the following page. The short display includes manufacturer, model, battery type, charging cycle, actual voltage and target voltage. This display cycles continuously during regulator operation.



Figure 4 - Proper attachment of optional battery and alternator temp sensors at the regulator.

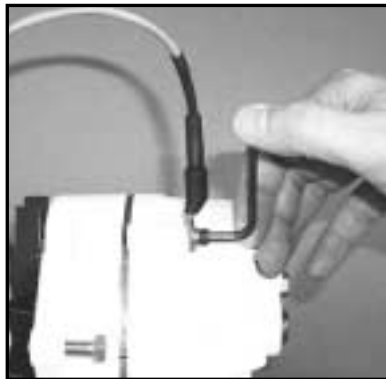

Figure 5 - Mounting temperature sensor mid-case on small case alternator.



Figure 6 - Mounting temperature sensor on battery.

ALARM OUTPUT FUNCTIONS

Alarm Output (Dash Lamp)

(-) 0.5 amp - when in alarm mode

- Low battery voltage (030)
- High battery voltage (040)
- High temperature at battery #1 (020)
- High temperature at battery #2 (021)
- High temperature at alternator (022)

Aux. #1 (Advisory) Output

(-) 0.5 amp - when in alarm mode

- Alt. output at full capacity
- Small engine option activated (051)
- Equalization mode activated

Figure 7 - Alarm output functions.

VI. PRESET BATTERY PROGRAMMING

In addition to its Universal (default) factory program, which can be used safely with most battery types, the MC-612 features programs for: gel, standard lead acid, deep-cycle lead acid, AGM (absorbed glass mat), Optima (spiral), as well as voltage-sensitive (halogen) applications.

'ACTIVATE-RELEASE' Refers to the activation and immediate deactivation of the switch by lowering a magnetic tool (such as a pocket screwdriver with a magnetic tip – see Figure 9) onto the upper corner of the switch, and immediately deactivating the switch by removing the magnet from the switch. An LED dot, described in Figure 9 will indicate switch activation.

'ACTIVATE-HOLD ... RELEASE' Typically used during programming, this action requires holding the magnet to the switch until desired values are shown on the display. Once the desired setting is reached, the magnet is removed to deactivate the switch.

Note: Program function will alternately cycle up or down each time the PrA Mode is activated. If you miss your desired program value, release the switch and re-activate, the cycling direction will automatically change. Any advanced programming values will be retained within the regulator's memory until the preset battery programming is reset.

The MC-612 is equipped with a magnetic reed switch, embedded in the epoxy potting, which activates the regulator's programming. The switch works in two specific actions, described in the shaded box below:

To set the regulator for your desired battery program:

1. 'ACTIVATE-HOLD' the switch. The display will show the "Pro" mode, indicating that the Program mode has been activated.
2. 'HOLD' while the display scrolls, until the numeric equivalent to your battery type is displayed on the LED screen. See Figure 10 to determine which selectable preset program is most desirable for your battery technology. Figure 11 provides detailed information regarding preset programs.
3. 'RELEASE' when the desired value is attained.
4. Once a value has been chosen, the display will return to the "Pro" mode. At this point, you can adjust, up or down, by repeating Steps 1 through 3 until the numeric display reflects your desired preset program.



Figure 9 - Operation of magnetic reed switch.

SD Mode 1 - Manufacturer name. Readout displays "BAL".	
SD Mode 2 - Regulator model. Readout displays "612".	
SD Mode 3 - Battery type. Readout displays program currently in memory.	
SD Mode 4 - Battery type. Readout displays abbreviated battery type.	
SD Mode 5 - Charging stage. Shows current stage of charging cycle. See Figure 12 on Page 5.	
SD Mode 6 - Battery voltage. Displays current battery voltage state.	
SD Mode 7 - Calculated voltage. Readout displays voltage target based on charging stage.	

Figure 8 - Short display (SD).

1 Universal Factory Program (UFP) . For multiple battery types.	
2 Flooded Deep Cycle (Fdc) . For deep-cell lead acid batteries.	
3 Sealed Gel Cell (GEL) . For sealed gel batteries.	
4 Absorbed Glass Mat (AGL) . For AGM batteries.	
5 Optima (OPS) . For Optima spiral wound batteries.	
6 Flooded Standard (FSB) . For standard lead acid batteries.	
7 Halogen (HAL) . For voltage sensitive applications.	

Figure 10 - Selectable battery presets.

If no changes are made, the program you have selected will be locked into permanent memory until modified. The "SAV" code will be displayed, indicating the program has been locked into memory.

Primary Program Settings	PRG-1 Universal Factory Program	PRG-2 Deep Cycle Flooded Lead Acid	PRG-3 Gel Cell	PRG-4 Absorbed Glass Mat (AGM)	PRG-5 Optima Spiral Wound	PRG-6 Standard Flooded Lead Acid	PRG-7 Halogen Voltage Sensitive
Mode							
Start Delay (Seconds)	45	45	45	45	45	45	45
Ramp Up (Seconds)	60	60	60	60	60	60	60
Bulk Voltage (Max)	14.10	14.60	14.10	14.38	14.60	14.40	14.00
Bulk Time (Minimum)	36 min.	36 min.	36 min.	36 min.	36 min.	36 min.	36 min.
Absorption Voltage	13.90	14.40	13.90	14.18	14.40	14.20	13.80
Absorption Time (Minimum)	36 min.	36 min.	36 min.	36 min.	36 min.	36 min.	36 min.
Float Voltage	13.42	13.35	13.70	13.38	13.40	13.40	13.50
Float Time (Maximum)	6 hr.	6 hr.	6 hr.	6 hr.	6 hr.	6 hr.	6 hr.
High Voltage Alarm	15.20	15.60	15.10	15.38	15.60	15.40	15.00
Low Voltage Alarm	12.80	12.80	12.80	12.80	12.80	12.80	12.80
Max Battery Temperature	125F/52C	125F/52C	125F/52C	125F/52C	125F/52C	125F/52C	125F/52C
Max Alternator Temperature	225F/107C	225F/107C	225F/107C	225F/107C	225F/107C	225F/107C	225F/107C
Equalization (User Prog.)	Yes	Yes	No	No	No	Yes	No

Figure 11 - Preset program values. Voltages shown may vary by +/- 3% from values shown.

Advanced Programming and Diagnostics

BALMAR®

VII. ADDITIONAL DISPLAYS

Charging Stages

The MC-612 uses up to 12 individual stages to ensure proper charging. Each stage may contain a specific voltage or time value, or a combination of values. These stages are displayed in both Short and Long Display modes, and are described in Figure 12.

Long Display

To access the Long Display, 'ACTIVATE-RELEASE' the reed switch while the Short Display is cycling. The numeric LED will immediately return to the "BAL" code and start cycling through the Long Display. See Figure 13 for code definitions.

Once the Long Display has cycled through all of its information modes, the display will automatically revert to the Short Display.

VIII. ADVANCED PROGRAMMING

Advanced programming levels can be accessed in Long Display mode. To access:

1. With regulator in Long Display mode, **ACTIVATE-HOLD** until the "Pro" display code appears. **RELEASE**. The "PrA" display code will appear.
(CAUTION: If the switch is held too long, the regulator will return to the preset program adjustment mode). Once in advanced program mode, the display will cycle through the various advanced programming modes (see Figure 14).
2. When the desired advanced program mode is reached, **ACTIVATE-HOLD**. The display will scroll through the available time or voltage value selections.
3. **RELEASE** when desired values are reached. Inversely, the values can be decreased, if desired. **ACTIVATE-HOLD** while values decrease. **RELEASE** when desired value is attained.
4. The PrA mode will cycle 3 times. Any changes made during those cycles will be saved.

Figure 12 - Charge stage codes as seen in Long Display.

Stage 1 - Start Delay. Provides a 45-second delay before load is placed on engine and belts. Adjust time in PrA*.		Stage 7 - Calculated Absorption. Time varies by state of charge at end of Stage 6. Adjust in PrA*.	
Stage 2 - Soft Ramp. One minute voltage ramp minimizes belt slippage. Non-adjustable.		Stage 8 - Ramp Down. Transition from Absorption to Float stage. Non-adjustable.	
Stage 3 - Bulk. 30-minute set period. Program determines charging voltage. Time/voltage adjustable in PrA*.		Stage 9 - Float. 30-minute time period. Program sets charging voltage. Time/volts adjust in PrA*.	
Stage 4 - Calculated Bulk. Time varies by state of charge at end of Stage 3. Adjustable in PrA*.		Stage 10 - Calculated Float. Time & voltage based on state of charge at end of Stage 9. Adjust in PrA*.	
Stage 5 - Ramp Down. Transition from Bulk to Absorption stage. Non-adjustable.		Stage 11 - Ramp to Equalize. Batteries should be at full charge before initiating equalization.	
Stage 6 - Absorption. 30-min. set time. Preset program sets charging voltage. Time/voltage adjusts in PrA*.		Stage 12 - Equalization. Time and Voltage adjustable in PrA*. See battery mfg. limits for time and voltage values. User set.	

PrA* - Time and/or voltage adjustments can be made in the Advanced Program mode.

Figure 13 - Long Display (LD) attributes as displayed on digital numeric readout.

LD Mode 1 - Readout displays "BAL" (Short for Balmar.)		LD Mode 9 - Battery #1 temp. Followed by the sensor reading in degrees(Celcius).	
LD Mode 2 - Regulator model. Readout displays "612".		LD Mode 10 - Battery #2 temp. Followed by the sensor reading in degrees(Celcius).	
LD Mode 3 - Program level. (P) Displays program currently in memory.		LD Mode 11 - Factory use only.	
LD Mode 4 - Battery type. Readout displays abbreviated battery type. See Figure 10 for descriptions.		LD Mode 12 - Factory use only.	
LD Mode 5 - Charging stage Displays the specific stage of the charging cycle. See Figure 13 for descriptions.		LD Mode 13 - Run time. "Hr" code is followed by a numeric readout in 1/10-hr increments.	
LD Mode 6 - Battery voltage. Shows current system voltage.		LD Mode 14 - Tach reading. Activate and adjust for alternator pole type in advanced programming.	
LD Mode 7 - Calculated (Target) voltage based on program mode.		LD Mode 15 - Explanatory mode. May be followed by one or more diagnostic codes. See Figure 17.	
LD Mode 8 - Revision number. Displays software version.			

Figure 14 - Advanced Programming (PrA) as displayed on digital numeric readout.

PrA Mode 1 - Advanced program mode indicator.		PrA Mode 7 - Float voltage control "Fv". Followed by time reading. Adjust up or down.	
PrA Mode 2 - Start delay "DL". Adjusts seconds before ramp up.		PrA Mode 8 - Float time control. "Fc" code is followed by time reading. Adjust up or down.	
PrA Mode 3 - Bulk voltage control. "Bv" code is followed by volt reading. Adjust up or down.		PrA Mode 9 - Amp Manager control. See details for Amp Manager on following page.	
PrA Mode 4 - Bulk time control. "Bc" code is followed by time reading. Adjust up or down.		PrA Mode 10 - Equalization Voltage control. See details for Equalization on following page.	
PrA Mode 5 - Absorption voltage control. "Av" code is followed by volt reading. Adjust up or down.		PrA Mode 11 - Equalization Time control. See details for Equalization on following page.	
PrA Mode 6 - Absorption time control. "Ac" code is followed by time reading. Adjust up or down.		PrA Mode 12 - Alternator Constant. Emulates tachometer reading. See following page for adjustment.	
		PrA Mode 13 - Compensation Limit. Limits max. temperature compensation. See following page.	

Amp Manager (AP)

The Amp Manager function enables you to reduce the alternator output by controlling the voltage at the field wire. This feature can be used as a method to minimize alternator overheating in warmer climates, as well as minimizing difficulties with chronic belt slippage. To adjust Amp Manager values:

1. 'ACTIVATE-RELEASE' when display cycles to "AP" (PrA Mode 09). "AP" will be followed by "OFF" code.
2. 'ACTIVATE-HOLD' "OFF" display cycles to "249". The value "249" represents full field output. The numeric value on the display will decrease until you RELEASE.

Note: The value "200" represents approximately 75% field output, "150" represents approximately 50% field output, and "75" represents approximately 25% field output.

Equalization Mode (EQ)

Allows increase in charging voltage to minimize battery sulfation. (**Equalization is ONLY suggested for batteries noted as "equalization friendly" in Figure 11 on Page 4**). Consult your battery manufacturer for equalization time and voltage recommendations. Equalization must be initiated through the advanced programming. It is NOT a standard mode of operation. Once equalization voltage and time values are saved into the regulator's programming, the equalization process will start immediately. Once equalization has occurred, the regulator will revert to its preset program status. The user will need to re-activate equalization mode for subsequent anti-sulfation conditioning. For system safety, equalization voltage is limited to 15.8 volts.

To adjust equalization voltage (PrA Mode 10):

1. 'ACTIVATE-RELEASE' "PrA" display cycles to "Ev" followed by "OFF" code.
2. 'ACTIVATE-HOLD'. "OFF" display cycles to numeric voltage values. When the manufacturer-recommended voltage is reached, RELEASE.

To adjust equalization time (PrA Mode 11):

1. 'ACTIVATE-RELEASE' "PrA". Display cycles to "Ec" followed by "OFF" code.
2. 'ACTIVATE-HOLD'. "OFF" display cycles to numeric equalization time values. When the manufacturer-recommended time value is reached, 'RELEASE'.

Alternator Constant Mode (ALC)

Emulates tachometer readings on regulator display. Must be activated in Advanced Programming. To determine proper calibration value, divide 384 by the number of poles in your alternator. (A 14-pole alternator has a calibration value of 27.)

To enable ALC (PrA Mode 12):

1. 'ACTIVATE-RELEASE' "PrA" display cycles to "ALC" followed by "OFF" code.
2. 'ACTIVATE-HOLD'. "OFF" display cycles to numeric calibration values. When the proper calibration value is reached, RELEASE.

Compensation Limit (CL)

When equipped with optional Battery Temperature Sensor, the MC-612 will automatically adjust charging voltage to compensate for ambient battery temperature. In default mode, the regulator is limited to maximum compensated voltage of 14.8 volts (to minimize the likelihood of over-voltage shutdown by inverters and combiners). Compensation Limit allows the user to advance or decrease maximum compensated voltage to suit specific charging system needs.

To enable CL (PrA Mode 13):

1. 'ACTIVATE-RELEASE' "PrA" display cycles to "CL".
2. 'ACTIVATE-HOLD'. Default voltage value of 14.8 cycles to increasing voltage values. To decrease voltage values, RELEASE, wait for the voltage value to disappear. Re-activate and hold. When the proper voltage value is reached, RELEASE.

Explanatory / Advisory Codes

Descriptions for these codes can be found in Figure 17. For additional technical information, see our Technical Support pages at the Balmar website (<http://www.balmar.net>). To reset advisory/diagnostic codes, access the Advanced Programming mode as described at the beginning of Section VIII. No changes need to be made to programming once the Advanced Programming mode is accessed. AP mode will cycle three times and return to normal mode. Codes will automatically reset when AP mode is complete.

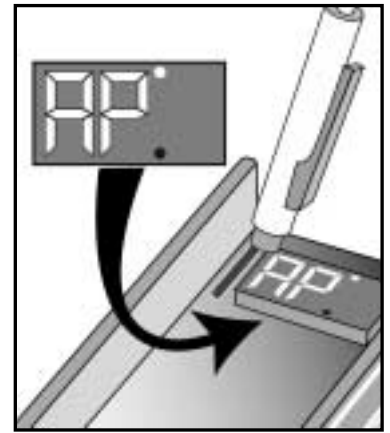

Figure 15 - Indicates Amp Manager Mode.

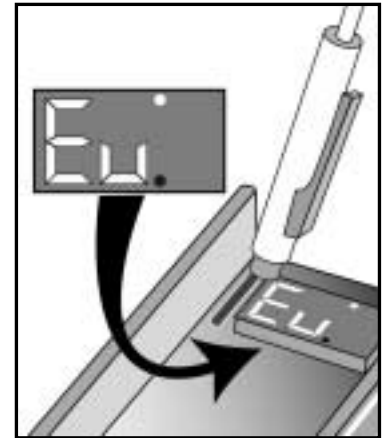

Figure 16 - Equalization Voltage mode is activated.

CODE 001	Factory use only.
CODE 002	Factory use only.
CODE 010	Wire short at battery #1 temperature sensing terminal.
CODE 011	Sensor wire not found at battery #1 temperature sensing terminal.
CODE 012	Wire short at battery #2 temperature sensing terminal.
CODE 013	Sensor wire not found at battery #2 temperature sensing terminal.
CODE 014	Wire short at alternator temperature sensor terminal.
CODE 015	Sensor wire not found at alternator temperature sensor terminal.
CODE 020	Battery #1 exceeding recommended temperature limits.
CODE 021	Battery #2 exceeding recommended temperature limits.
CODE 022	Alternator exceeding recommended temperature limits.
CODE 024	Factory use only.
CODE 030	Voltage too low at battery.
CODE 031	Factory use only.
CODE 032	Factory use only.
CODE 040	Voltage too high at battery.
CODE 041	Factory use only.
CODE 042	Factory use only.
CODE 050	Open field.
CODE 051*	Small Engine Mode activated.
CODE 052*	Amp manager is in operation.

Underlined codes represent those pertaining to Alarm Output (dash lamp) operation.

Codes highlighted by an asterisk () pertain to Aux. #1 advisory output.*

Figure 17 - Advisory/diagnostic codes.

IX. SYSTEM TROUBLESHOOTING

Determining the causes of failures in an electrical system is a “step by step” process. We recommend that you inspect and clean all system electrical connections before you begin your search to determine if the failure can be attributed to one of the two main components of your charging system: the alternator, and/or the voltage regulator.

Most charging system problems will be corrected by performing the following steps.

1. Remove and clean all charging system electrical connections from the alternator through the batteries (this includes the ground side). Also, check the voltage regulator’s harness for resistance. Wires and terminals can and will become corroded and need to be cleaned or replaced.
2. Charge all batteries to their proper fully charged state and determine if they are serviceable. If your batteries are flooded-type, use your hydrometer to determine their condition.
3. Check and tighten alternator belt. If the belt shows signs of wear or damage, now is an ideal time for replacement. Always replace existing belts with the finest quality replacements available.

After determining that your batteries and wiring are in suitable condition, use the following tests to determine if charging problems are a result of a faulty alternator or regulator. The following tests provide an opportunity to isolate the alternator, regulator and wiring harness in order to determine which component may be malfunctioning. In order to perform these tests, you will need an independent multimeter (preferably a digital type). In an emergency, a 12V light bulb can be used to help determine if power or working grounds exist. An amp meter and a battery hydrometer with a thermometer are also helpful diagnostic tools.

Alternator /Regulator Field Tests

Test A - The alternator and regulator can be tested for function by determining if a magnetic field exists at the alternator’s pulley shaft or rear bearing. To test:

1. With the ignition in the OFF position, place the head of a steel screwdriver near the nut on the pulley shaft or near the rear bearing of the alternator. There should be no evidence of a magnetic field pulling the screwdriver toward the alternator.
2. Engage the ignition, without starting the engine, to activate the voltage regulator. If an oil pressure switch is used, a jumper across the switch will activate the regulator.
3. After allowing time for the regulator’s start-up delay, place the head of a steel screwdriver near the nut on the pulley shaft or near the rear bearing of the alternator. There should be evidence of a magnetic field pulling the screwdriver toward the alternator. If a magnetic field is present, the voltage regulator, alternator brushes and rotor are likely to be working properly. If the system is not charging, remove the alternator and have it inspected by a qualified alternator shop.

Test B - If there is little or no magnetic pull at the pulley shaft or at the rear bearing, initiate the following test:

1. With the key off and the engine off, remove the large harness plug from the regulator.
2. Insert the end of a short length of electrical wire to the RED connector slot of the regulator harness and the other end of the wire to the BLUE connector slot. (See Figure 18.) This bypasses the regulator and tests the alternator and the harness.
3. Using your steel screwdriver, inspect for a magnetic field as described above.
4. With your voltmeter, check for voltage on the blue wire at the alternator. If voltage does not exist, the harness may be at fault. If voltage does exist at the harness, but charging is not occurring, the alternator is likely to be malfunctioning.

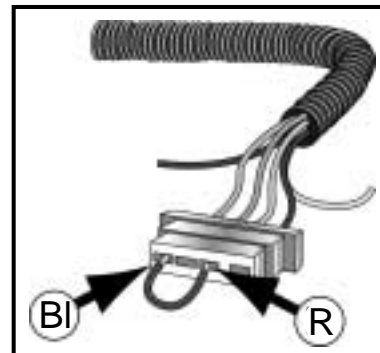

Figure 18 - Jumping power wire to field.

If a magnetic field is present. Both harness and alternator brushes and rotor appear to be working properly. If no magnetic field is present, proceed with the next test.

Test C - Testing the actual output of the alternator is known as “Full Field Testing”. This can be accomplished by jumping a positive 12VDC current to the field terminal at the rear of the alternator. This test eliminates both the regulator and the harness, making it easier to isolate your investigation to the alternator. CAUTION: Ensure that all voltage sensitive equipment is turned off prior to starting the engine. Voltage is unregulated during this test and could damage sensitive electronics. DO NOT let the engine run any longer than necessary to detect charging.

To test the alternator:

1. Clip a jumper wire to the positive post of the alternator, or on the battery side of the isolator, if an isolator is in use. Use a SHIELDED alligator clip for post attachment. Unintentional contact between the alligator clip and the alternator case could result in damage to your electrical system.
2. Disconnect the field/stator plug from the rear of the alternator and attach the other end of the jumper wire to the alternator’s Field terminal (F). Attach a female spade connector to the field end of the wire for a solid connection. CAUTION: Do not allow the wire to contact the case while it is attached to the positive post. The case is grounded and severe damage could occur.
3. The regulator is now bypassed. When the ignition is engaged and the motor is started, the voltage should rise and charging current should be present.
4. The motor should be run long enough to determine that charging voltage is present. Unregulated voltage can rise quickly. Do not allow extended unregulated charging to occur without carefully monitoring voltage levels.

If the alternator fails to generate voltage during field testing, a malfunction of the alternator is likely. Contact your local alternator repair shop or Balmar’s technical service staff for recommendations.

Voltage Regulator Test

When you have inspected and repaired any wires and connections, inspected belts and replace as needed, and after you have determined that your batteries are properly charged, set your voltmeter to 12V and connect the voltmeter's negative lead to the BLACK ground wire at the regulator. Normally, connection is accomplished by inserting the negative lead alongside the ground wire in the regulator harness plug (see Figure 19) and the positive lead alongside the wire referred to in each specific test. With the voltmeter securely connected to the regulator's ground, test for voltage at the points listed below.

1. With the ignition in the OFF position and your voltmeter's ground wire connected to the regulator's ground, check for voltage on the red (sensing), blue (field) and brown (ignition) wires in the regulator plug by inserting the positive lead of the voltmeter alongside each wire in the regulator harness plug. The voltmeter should read:

Expected Reading	Red Wire	Brown Wire	Blue Wire
Your Reading	12 V *	0 V	0 V

2. With the ignition in the ON position (engine not running) and your voltmeter's ground wire connected to the regulator's ground, check for voltage on the red (sensing), blue (field) and brown (ignition) wires in the regulator plug. The voltmeter should read:

Expected Reading	Red Wire	Brown Wire	Blue Wire
Your Reading	12 V*	12 V	7 - 12 V

3. With the ignition in the ON position (with engine running at 1,400 rpm fast idle) and your voltmeter's ground wire connected to the regulator's BLACK wire, check for voltage on the red (sensing), blue (field) and brown (ignition) wires in the regulator plug. The voltmeter should read:

Expected Reading	Red Wire	Brown Wire	Blue Wire
Your Reading	12 - 14V**	12 V	4 - 12 V

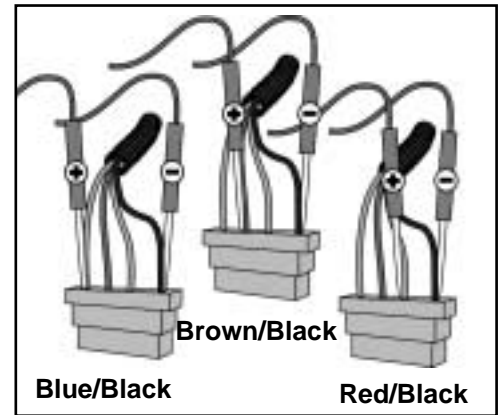

Figure 19 - Inserting voltmeter probes.

* 11.5 - 12.8 VDC battery voltage at rest (no charging occurring). If your batteries are isolated and your RED (sensing) wire shows voltages other than those shown above, make sure that the wire is connected on the "battery" side of the isolator. The RED wire must "see" the battery directly.

** 13.5 - 14.5 VDC battery voltage when charging.

If your readings differ substantially from the "Expected Readings" listed in the charts above, the regulator may be malfunctioning, or there may be a continuity problem. Contact our technical support staff at (360) 435-6100. Keep your recorded readings in the spaces provided below the "Expected Readings" so you can share them with the technical support person. If your readings match those listed in the charts, your regulator should be working correctly. Continue with tests below to determine if your alternator may be the source of charging difficulties. If the preceding tests do not prove the existence of a failure within the regulator or alternator, we recommend you contact a licensed marine electrician who can test your system for wiring and circuit damage or other system failures that could be responsible for charging difficulties. If you determine that repair service is necessary for either your alternator or regulator, please gather the following information before contacting our service technicians.

1. Model of alternator.
2. Model of voltage regulator.
3. Voltage readings on red, brown and blue wire at regulator with engine off, key on.
4. Voltage readings on red, brown and blue wire at regulator with engine running at a fast ideal 1400 rpm.

XII. LIMITED PRODUCT WARRANTY

BALMAR warrants to the original consumer/purchaser the product is free from any defects in material or workmanship for a period of one year from the date of purchase. If any such defect is discovered within the warranty period, BALMAR will replace the regulator free of charge, subject to verification of the defect or malfunction upon delivery or shipping prepaid to BALMAR.

This warranty DOES NOT apply to defects or physical damage resulting from abuse, neglect, accident, improper repair, alteration, modification, or unreasonable use of the products resulting in breakdown, cracked or broken cases nor are parts damaged by fire, water, freezing, collision, theft, explosion, rust, corrosion or items damaged in shipment in route to BALMAR for repair. BALMAR assumes no responsibility for consequential damage or loss or expense arising from these products or any labor required for service or repair.

BALMAR WILL NOT repair or be held responsible for any product sent without proper identification and return address or RA number clearly marked on the package. You must include proof of date and place of purchase (photocopy of purchase invoice) or we cannot be responsible for repairs or replacement. In order to expedite warranty claims more efficiently, BALMAR asks that prior to returning a defective product for repair, you call their customer service department for a warranty return authorization number.

If factory service is required, you can contact our BALMAR Customer Service Department Monday through Thursday, 7:30 AM to 5:30 PM, (PST) 1-360 435-6100 ext "3".

Material required for the repair or replacement for the defective part or product is to be supplied free of charge upon delivery of the defective regulator to BALMAR, 19009 61st Ave. NE, Arlington, WA 98223. Customer is responsible for all return transportation charges and any air or rush delivery expense. BALMAR reserves the right to determine whether to repair or replace defective components.

THE ABOVE LIMITATIONS MAY NOT APPLY TO YOU. SOME STATES DO NOT ALLOW LIMITATIONS ON HOW LONG AN IMPLIED WARRANTY LASTS. NO PERSON, AGENT, DEALER IS AUTHORIZED TO GIVE ANY WARRANTY.

BALMAR 19009 61st Ave. NE, Arlington, WA 98223 Phone: (360) 435-6100, Fax: (360) 435-3210
E-mail: balmar@balmar.net, Web: www.balmar.net

Single Output Two battery Banks

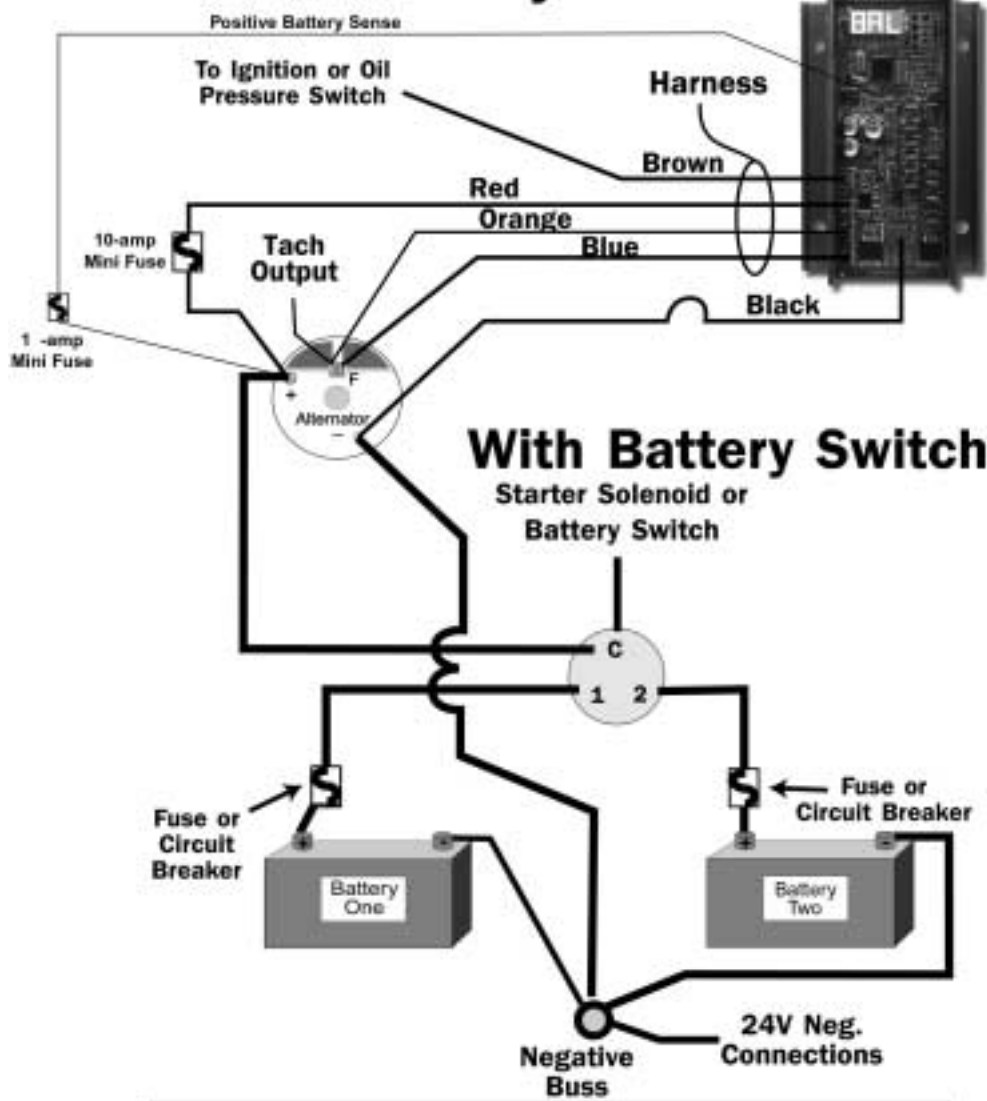

With Isolator (Three Bank)

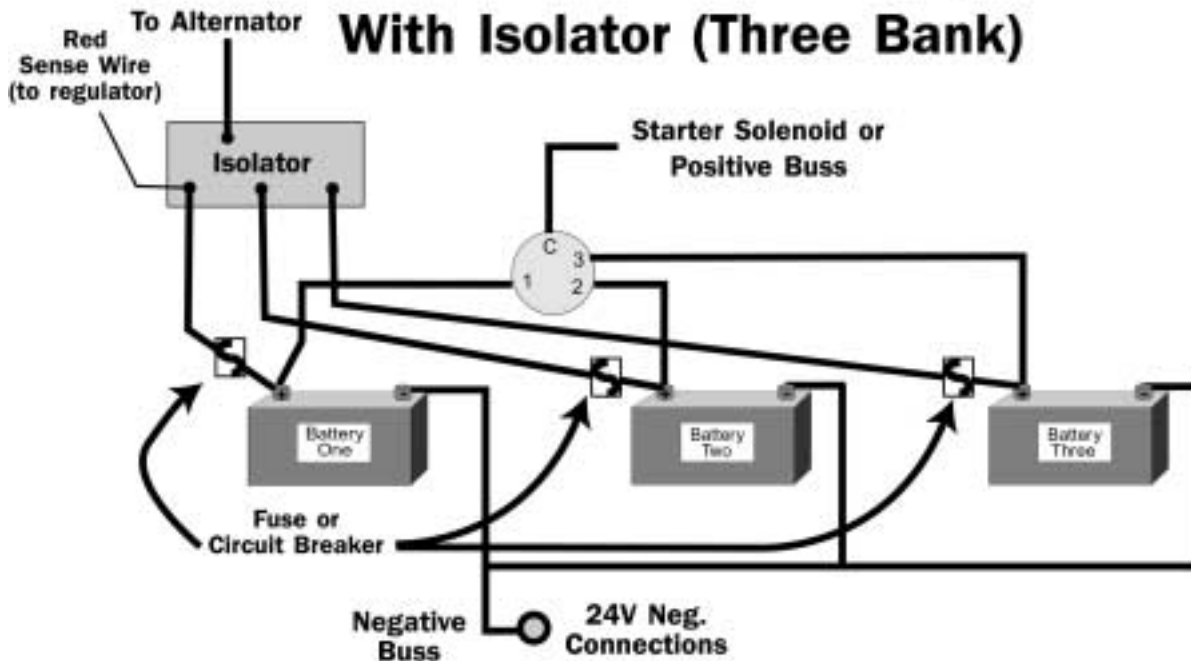

Suggested Wiring Options for Dual Output Alternators

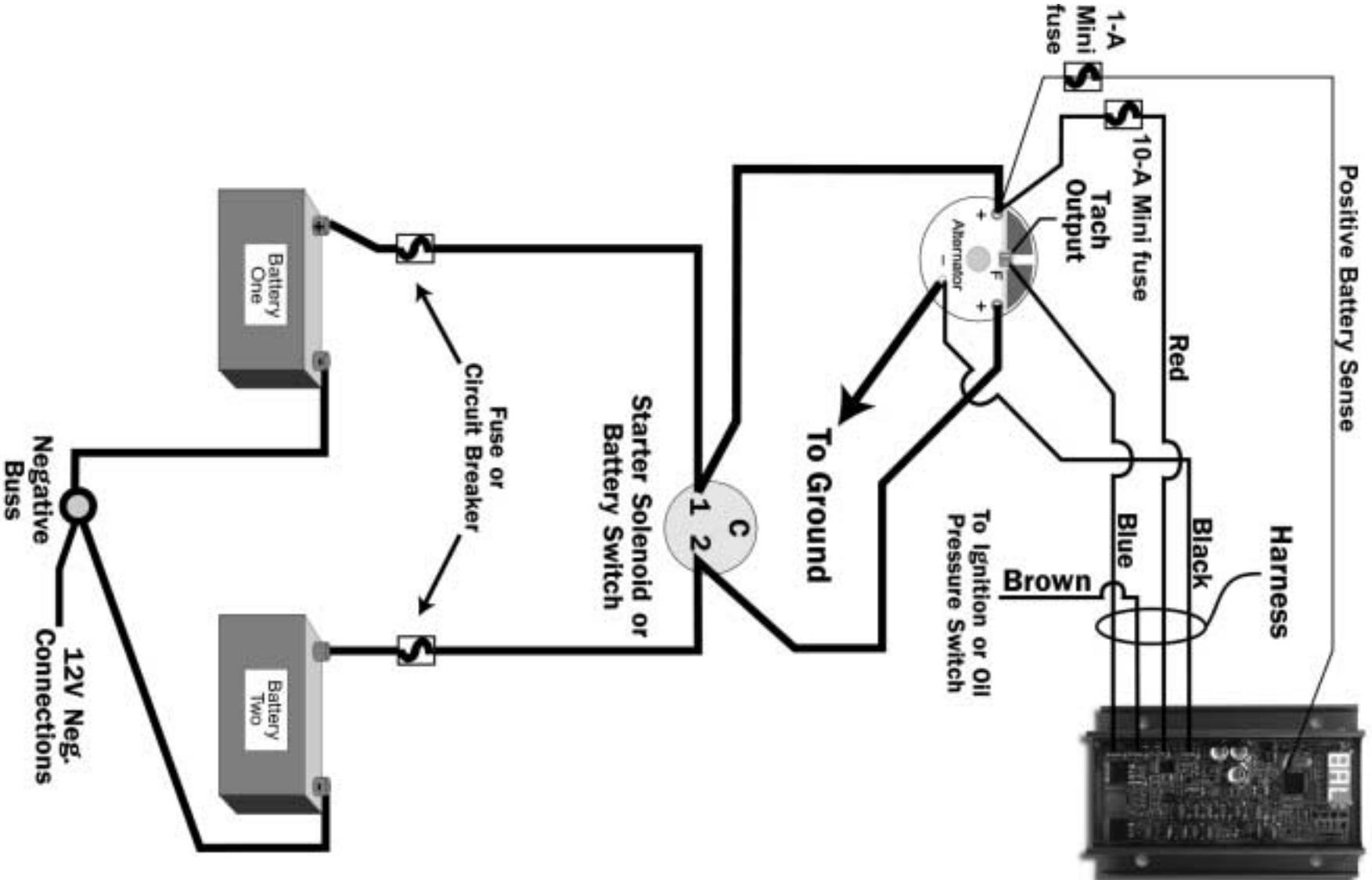

Max Charge MC-612

Quick Installation Instructions



BALMAR®

IMPORTANT

The following information is essential to the proper operation of your Max Charge regulator. Do not install or operate before reviewing the following:

- 1. Positive Battery Sense Wire** - User supplied – not in harness. This wire must be connected to the regulator and to a source of positive battery voltage (see #3 on reverse for mounting location) to provide proper regulator operation. The regulator WILL NOT WORK if the Positive Battery Sense Wire is not connected to the regulator and is not sensing battery voltage. The Positive Battery Sense Wire must be fused. A 1/8-amp fuse is included with the regulator and harness kit.
- 2. Grounding** - The Model MC-612 must be properly grounded to regulate accurately. The two ground wires located in the harness must be securely attached to their terminals and the alternator's preferred ground to ensure proper grounding. A grounding strap between the alternator's preferred ground and the preferred ground at the engine is strongly recommended.
- 3. Voltage Readings** - MC-612 digital circuitry is engineered to monitor battery charge state and automatically compensate for changes in battery voltage during operation. As a result, it is NOT unusual to see near-constant changes in the regulator's Battery Voltage display. These voltage changes reflect the regulator's ability to make precise corrections to optimize charging efficiency.
- 5. Electrical Tachometers** - Many OEM and aftermarket tachometers require an AC pulse from the alternator to drive the tachometer. If you are using an electrical tachometer that is being driven off of your alternator's stator pulse, plug the white stator wire into the terminal provided on the regulator, and the tach feed into the Tach Out terminal. If you are not using the stator pulse to drive your tachometer, DO NOT plug the stator wire into the regulator's Stator connection.

When using the alternator and regulator to drive your tachometer, there is a possibility that you will see system voltage creeping up when your batteries are fully charged. This occurs as a result of the regulator's effort to provide a "blip" of voltage to the alternator to keep the tachometer feed activated. This voltage creep can usually be reduced or eliminated by increasing the load on the batteries, ie., turning on a few cabin lights or cabin fans, until the batteries are allowed to accept charging voltage.
- 4. Dual-Output Operation** - When using the MC-612 with a dual-output alternator it is essential to ensure that the regulator senses the largest battery bank. The positive Battery sense wire must be attached on the alternator output terminal connected to the larger battery bank. If your system includes a large house battery and a smaller starting battery, there is the possibility that the smaller battery may see excess surface voltage during charging. Ensure that your smaller battery is inspected regularly for electrolyte levels. If optional Battery Temperature Sensors are used, we recommend attaching the #1 Battery Temperature Sensor to the smaller bank. This ensures that the alternator output will be reduced if the starting battery temperature exceeds safe operating temperatures.
- 5. Alternator & Battery Temperature Sensors (optional)** - The optional Alternator Temperature Sensor monitors for over-temperature conditions at the alternator. If ambient temperatures outside of safe limits are detected, the regulator will reduce alternator output to 50% and will activate an alarm circuit. NOTE: This option is not intended to be used as part of regular operation. If circuit is activated, inspect and repair the system immediately. Optional Battery temperature sensing can compensate for both over-temperature conditions and for operation in conditions where ambient battery temperatures are below 26°(C) by varying field voltage. It is not unusual to see charging voltage rise safely above normal levels when battery temperatures are below 26°(C).
- 6. Magnetic Reed Switch** - Not all magnets are alike. You may find that one magnet will activate the reed switch with little effort, while another similar magnet may require a bit of maneuvering to find the switch's "sweet spot." If you have difficulty adjusting program modes, be sure to check for the dot at the top of the LED to ensure that you are activating the switch.

Max Charge MC-612 Quick Installation Instructions

BALMAR®

The MC-612 can be installed with very little difficulty if installation instructions are followed carefully. If you are unaccustomed to marine electrical installations, we recommend a licensed marine electrician. To install the MC-612:

1. Mount the regulator in a dry, well-ventilated location, well away from hoses and exhaust manifolds which may cause damage to the regulator or wiring. Avoid areas of heat and/or high vibration.
2. The RED wire (in the harness) powers the regulator. Attach at the positive output terminal at the back of the alternator. If an isolator is used, this wire must be located on the battery side of the isolator. On a 12V system, this wire can carry 8 amps and must be protected by a 10-amp fuse. A fuse is included with the wiring harness.
3. The POSITIVE battery sense wire, as shown in the illustration at right, monitors battery voltage. The positive sense wire should be connected 1) at the battery, if only one battery is being used; 2) at the "common" terminal of the battery selector switch for multi-bank charging; or 3) on the isolator terminal for the largest battery bank (if isolator is used). This wire is user supplied and should be 16-gauge. Spade and ring terminals, and a 1-A inline fuse are provided. The positive and negative sense wires **MUST** be connected for the regulator to work. Refer to regulator side label for terminal locations. Caution: Sense wires **MUST** always see the battery being charged. Be sure to observe polarity when connecting.
4. The BROWN (ignition) wire activates the regulator when +12VDC is applied to the system. Attach the BROWN wire to a switched +12VDC source. The auxiliary side of the ignition switch, or an independent (ungrounded) oil pressure switch are both acceptable connection points. A toggle switch may be added to this circuit to shut down the alternator load in cases where maximum propulsion is needed.
5. Attach the Ford-type harness plug to the regulator (see illustration). The second BLACK (ground) wire in the harness attaches to the Negative Battery Sense Terminal. Both BLACK wires attach to preferred ground terminal on the alternator.
6. Plug duplex plug with BLUE (field) and White (stator) wires into rear of alternator.

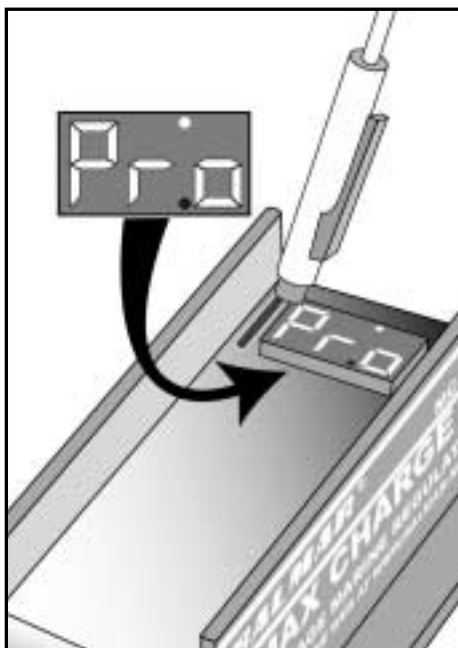
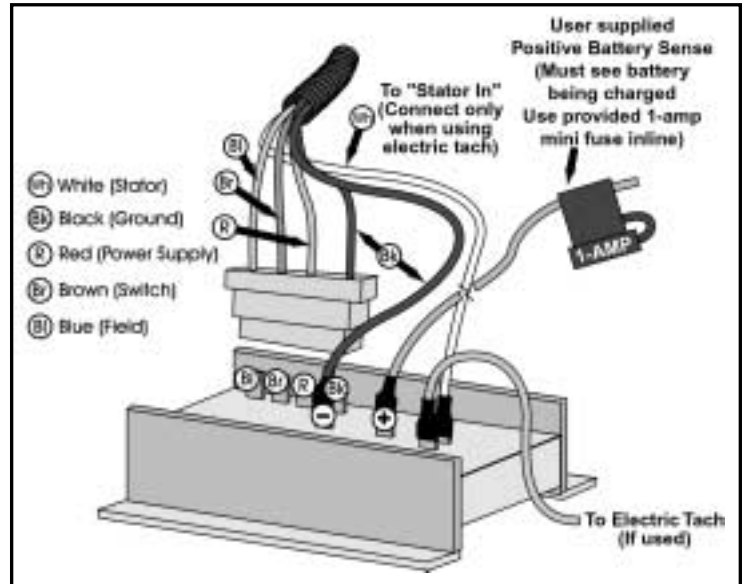

7. Plug the other end of the WHITE wire into the Stator Terminal on the regulator (see side label for locations of these and other terminals). Tach Terminal on the regulator provides pulse for electric tachometer, if desired.

The MC-612 is factory preset for use with most battery types. For optimal charging, we recommend choosing one of the six battery-specific selectable programs discussed on Page 4 of the installation manual. Program choices are: 1) Universal Factory Program, 2) Flooded Deep-Cycle, 3) Gel Cell, 4) AGM, 5) Optima, 6) Standard Flooded, and 7) for Halogen and voltage sensitive applications. To enter a battery program.

1. Activate the preset program mode by placing the magnetic screwdriver (or pencil magnet) as shown at left. The white dot at the top of the display indicates the switch is activated.
2. The "Pro" display appears, followed by the cycling of the battery type codes. When your desired battery type is displayed, release the switch by removing the magnet.
3. Should you need to alter your choice, activate the switch again with your magnet and release as soon as your desired program is displayed.
4. The "Pro" code will display, followed by the "SAV" code, once the switch is released. The regulator is now set for your battery type.